

300 x 300mm 'Versatac' Granite directional TGSIs or equivalent approved by Council installed on 25mm bedding mortar. Directional TGSIs are required if the distance is greater than 3000mm between the building line and the top of the ramp or if the ramp is not aligned with the building line.

300 x 300mm 'Versatac' Granite hazard TGSIs or equivalent approved by Council installed on 25mm bedding mortar. Hazard TGSIs shall be installed perpendicular to the pedestrian line of travel.

50mm wide x 40mm thick 'Panda' Granite inlay with exfoliated surface fixed with resin mortar by Eigen Stones, Bamstone, Melocco Stone or approved equal supplier.

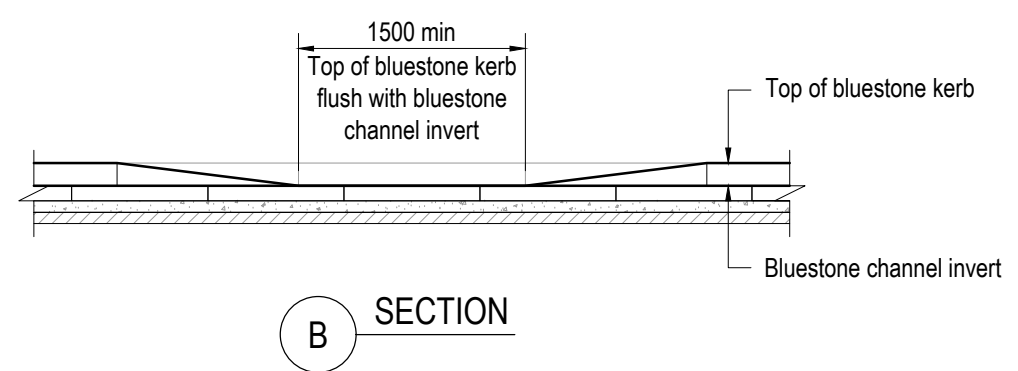
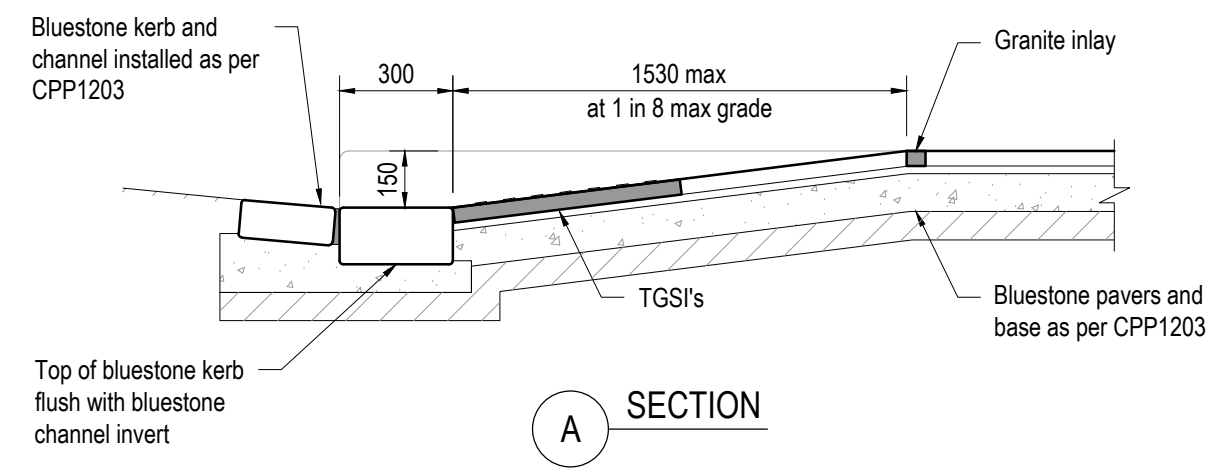

NOTES

1. Where the space between ramps is less than 500mm, joined ramps shall be used.
2. In corner situations where the pavement in one street differs from the other, extend the use of the higher quality material around the corner and make a transition at the side of the ramp.
3. Ensure that the design of all ramps and the provision of tactile ground surface indicators (TGSIs) are in accordance with: Australian Standard AS1428 (all applicable parts).
4. All dimensions are in millimetres unless noted otherwise.

A APPROVED FOR USE		DEC 2020
No	Revision	Date

Disclaimer:
The authors and sponsoring organisations shall have no liability or responsibility to the user or any other person or entity with respect to any liability, loss or damage caused or alleged to be caused, directly or indirectly, by the adoption and use of these Standard Drawings including, but not limited to, any interruption of service, loss of business or anticipatory profits, or consequential damages resulting from the use of these Standard Drawings. Persons must not rely on these Standard Drawings as the equivalent of, or a substitute for, project-specific design and assessment by an appropriately qualified professional.

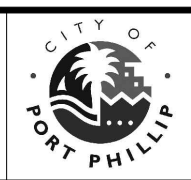

DRAWING NOT TO SCALE	
Approved	Project Services
Date	Dec. 2020

Drawing Title	DRESSED BLUESTONE KERB AND CHANNEL RAMP	
Original Size	A3	Drawing No: CPP1401
Rev:	A	